

LORO-X Scupper direct drain with basin

Individual components LORO-X Scupper drain, DN 100

with bonding flange for
bituminous roofing sheets

Drain article No. 01320.100X

Weight: 10,2 kg

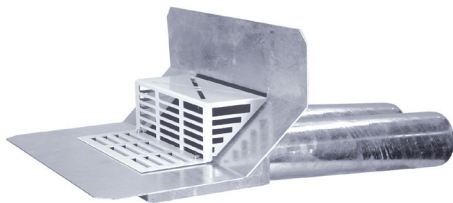

LX653-3X

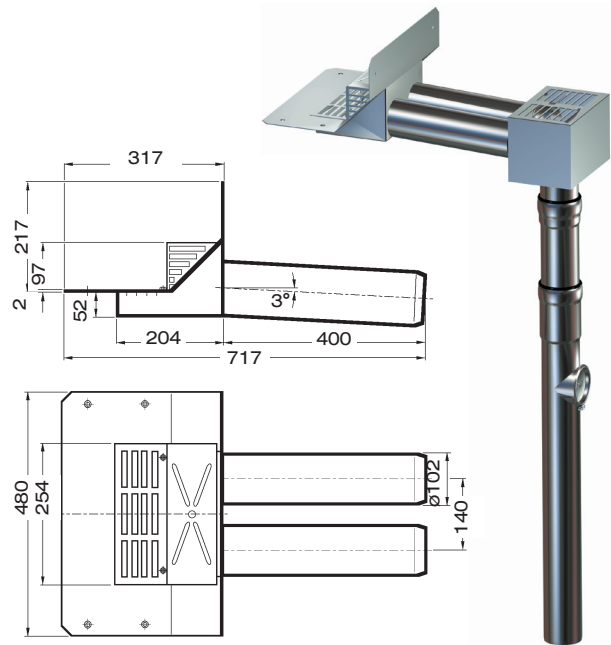

Individual components LORO-X sliding flange

for attaching the vapor barrier, fixed and loose flange
construction, made of galvanized steel,

including sealing element

Article no. 13228.100X

Weight: 4,9 kg

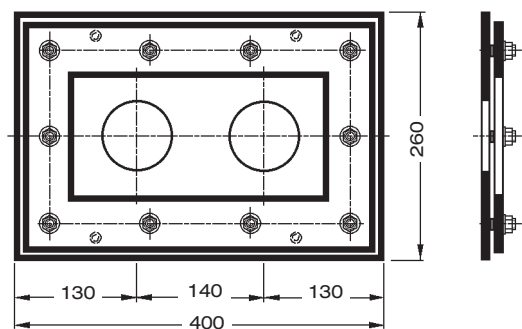
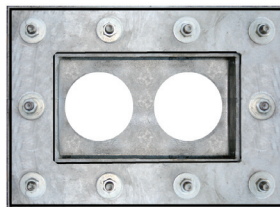

Heat tracing: Lorowerk recommends to check all drains and pipes with regard to their frost-sensibility. Where necessary, these parts should be upgraded with heat tracing.